

DATABLAD

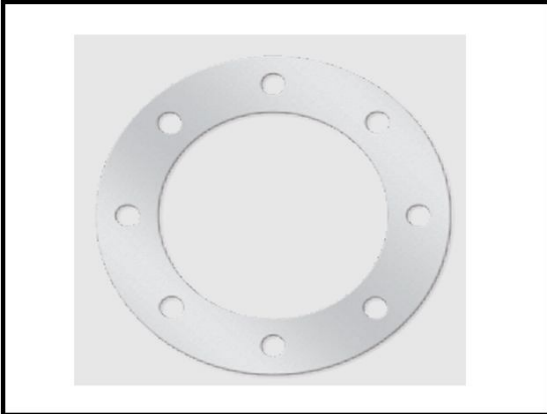

Løsfrens, galvanisert - PN10 EN 1092-1

PRODUKT BILDE



TEGNING MED MÅL

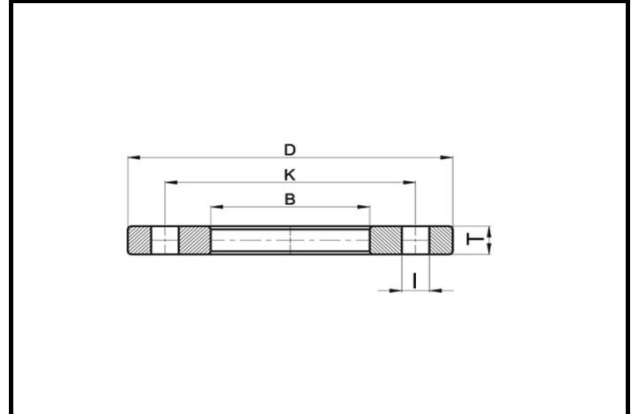

Serie

1258/20

AVK ref. nr.	NRF nr.	Rør diameter mm	DN mm	D mm	B mm	K mm	T mm	Antall boltehull	I mm	Bolt Diameter
GBR200X200NP10	2260041	200	200	340	235	295	10	8	22	M20
GBR225X200NP10	2260042	225	200	340	238	295	10	8	22	M20
GBR250X250NP10	2260043	250	250	395	288	350	15	12	22	M20
GBR280X250NP10	2260044	280	250	395	294	350	15	12	22	M20
GBR315X300NP10	2260045	315	300	445	338	400	20	12	22	M20
GBR355X350NP10	2260046	355	350	505	376	460	20	16	22	M20
GBR400X400NP10	2260047	400	400	565	430	515	25	16	26	M24
GBR450X450NP10	2260048	450	450	615	465	565	25	20	26	M24
GBR450X500NP10	2260049	450	500	670	517	620	25	20	26	M24
GBR500X500NP10	2260051	500	500	670	533	620	25	20	26	M24
GBR560X600NP10	2260052	560	600	780	618	725	25	20	30	M27
GBR630X600NP10	2260053	630	600	780	645	725	25	20	30	M27

Raw Material:

Galvanisert stål

Spigot Length:

N/A

Trademark:

N/A

Process Type:

Stansing

Application:

Vann og Gass

Standards:

Produsert iht. EN1092-1

FUSION PLASTICS LTD reserve the right to revise this product specification document, while maintaining compliance with the requirements of the product without prior notice. Tolerance on diameters and thickness according to the relevant standards unless otherwise specified. Tolerance: ±5%

Member of the **AVR** group

Opprettet dato:

KJMY/een 18/02/2019